

Modular Hygiene Station STAR CLEAN IV Compact Serie



Star Clean IV All in One Compact type 23893-1600

Controlled personnel hygiene

- Controlled process flow for hand and sole cleaning including disinfection
- Due to mandatory process flow, maximum hygiene is achieved before entering sensitive production areas
- Two tracks permitting access and exit for high personnel frequency
- The modular design permits customized solutions
- Depending on the available space, all variants can have a brush length of 1000 mm or 1600 mm
- Minimization of splashing water through pentagonal shaped step guide and optimized tread width
- The Star Clean IV Compact is available as a platform or built-in variant
- The platform versions can also be used as dry variants with dirt collection drawer (Bakery industry)
- The open hygienic design allows fast and efficient cleaning of all components

Why the Star Clean IV Compact!

- Controlled process flow assures optimal personnel hygiene
- Modular and flexible design for individual solutions
- Resistant brushes provide effective mechanical sole cleaning
- No tool for brush removal required
- Open design allows fast cleaning
- Possibility of integration into existing process chains for personnel hygiene

Option

- Module for sideways sole cleaning up to a height of approx. 4.5 cm
- Special feature for bakery industry: UVC-disinfection module for dry brush cleaning



Star Clean IV Compact type 23892-1000



Star Clean IV Compact

Hand and sole cleaning and disinfection, controlled by a motor-driven turnstile with high frequenting and low-maintenance.

The variety of this series allows customer tailored solutions.

Technical data

Type	23893-1600
Power supply	400V 3/N/PE
Power consumption	1.1-4.8kW
Main frequency	50-60Hz
Control voltage	24V DC
Protection class	IP65
Room temperature	Min. +4°C, max. +40°C
Water supply	Hot water 1/2" max. 65°C Cold water 1/2"
Drain	R2 1/2"

Technical data may be subject to changes

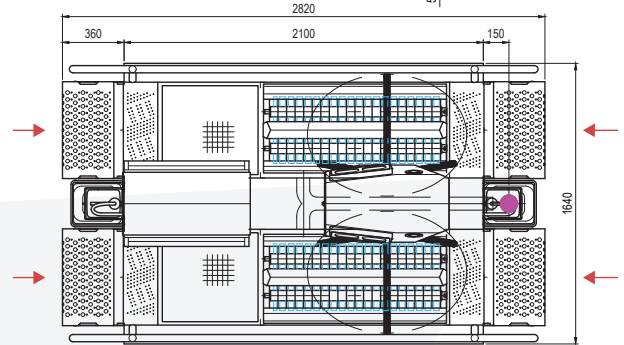
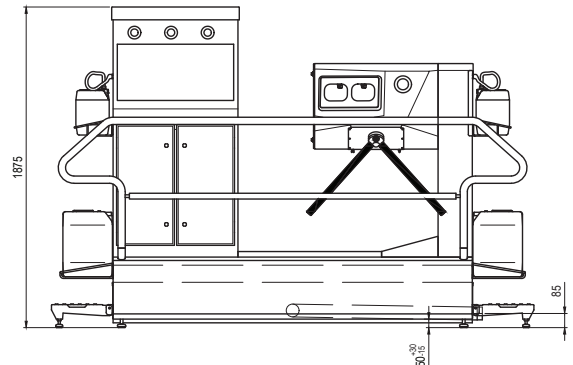

Example



Star Clean IV Compact type 23891-1600

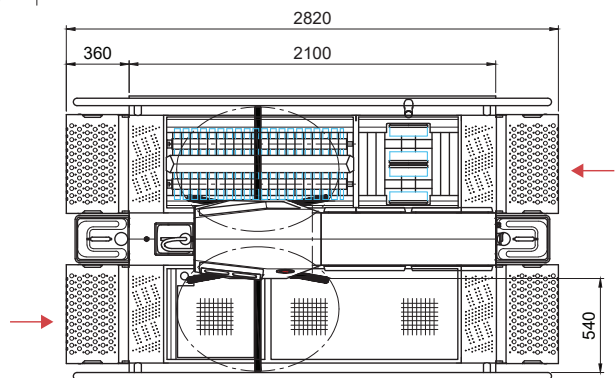
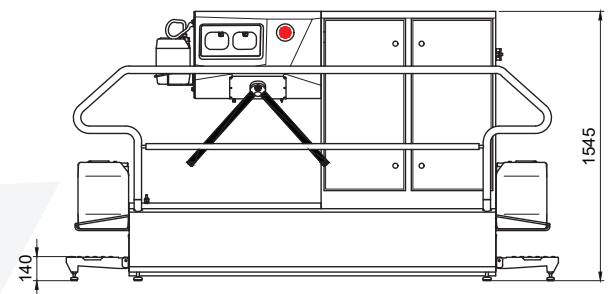

Example

Contact

CN: shanghai@frontmatec.com
Phone: +86 215 859 4850

DK: kolding@frontmatec.com
Phone: +45 763 427 00

NL: rijssen@frontmatec.com
Phone: +31 886 294 000

UK: birmingham@frontmatec.com
Phone: +44 121 313 3564

itec-hygiene.com
frontmatec.com

DE: hygiene@frontmatec.com
Phone: +49 252 185 070

ES: barcelona@frontmatec.com
Phone: +34 932 643 800

RU: moscow@frontmatec.com
Phone: +7 495 424 9559

US: kansascity@frontmatec.com
Phone: +1 816 891 2440