



Blade guiding

Frontmatec Circular knives in automatic cutting line

Daily grinding of the blade

Hygiene and maintenance

The equipment is designed to meet the high and strict demands in the meat industry. The knife blades are easy to maintain with a daily grinding, and can be send for resharpening several times, which gives a long lifetime and reduces maintenance costs.

Safety guarding

Frontmatec offers various solutions of safety guards, depending on customer preferences and product specifications.

Why the Frontmatec Circular Knives!

- Clean cuts
- Less bone dust
- Optimized yield through reduced product loss
- Longer shelf-life
- Improved ergonomics
- Hygienic cutting surface
- Better safety compared to using hand held tools

Technical data RSSL-260

Capacity	Depending on operator
Dimensions	Depending on conveyor etc.
Products	Pork neck / long loins
Product temperature	Min. 3°C - max. 7°C
Blade dimensions	Ø400
Voltage	3x400V, 50 Hz
Power	IN 5 Amp
Prefuse	10A

Technical data may be subject to changes. The equipment is CE approved and designed in accordance with the EU regulations to meet the strictest demand on health and safety.

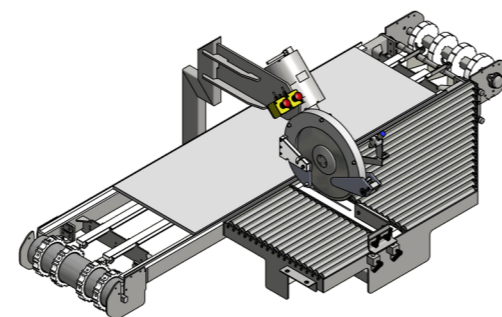

Neck cutting arrangement

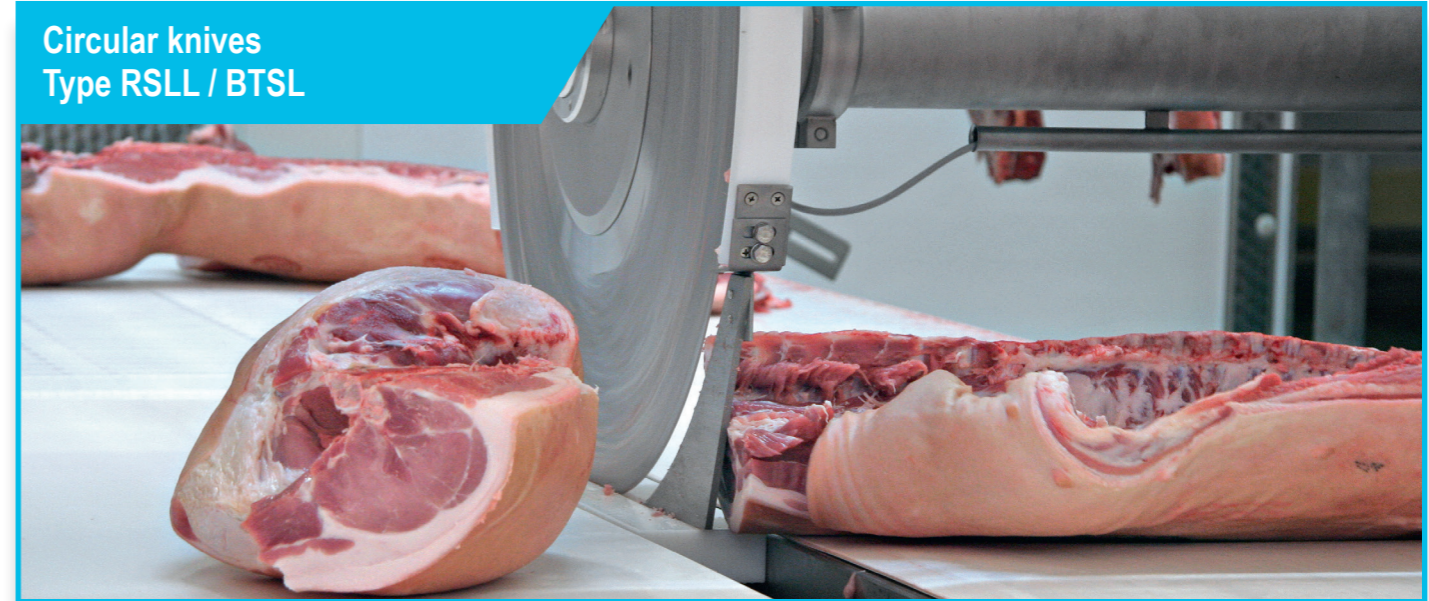

Circular knives
Type RSSL / BTSL

Circular knives for splitting of primals

Clean cuts with circular knives

Description

Frontmatec circular knives are available in different sizes for cutting of pork carcasses into primal cuts with the aid of a specially profiled edge for meat and bone, leaving a clean surface. Furthermore, Frontmatec offers circular knives for cutting off hind feet, multi cuts and cutting of long pork necks.

Type BTSL

For the manual cutting of pork hind feet, a stainless steel circular knife mounted on a laying down conveyor offers the best yield through a clean cut, and less bone dust.

The Frontmatec Hind Foot Knife has optional a support designed to be manually horizontally adjustable for ergonomic use.

The hind foot knife is delivered with a Ø400 mm knife blade, with a strong gear motor. The electrical control can either be integrated in a stainless-steel cabinet on the matching circular knife or be mounted separately on the hind foot knife in a plastic electrical cabinet.

Type RSSL-108-109-110

The Frontmatec Circular Knife can be delivered with a Ø750 mm knife blade for cutting of pork leg/shoulder, and with a Ø950 mm knife blade for cutting of sow leg/shoulder. The unit is also available with two different lengths of extension arm, depending on the width of the conveyor belt and the position of the carcass.

Type RSSL-260

For cutting off neck on long loins/chump integrated on a pace line Frontmatec offers the circular knife cutting arrangement type RSSL-260.

This unit offers better safety compared to handheld tools and can easily be fitted to an existing line. It is delivered with a Ø400 mm stainless steel blade and a holding device at the roller table, which is height adjustable for an optimal ergonomic workspace.

Type RSSL-301

The Frontmatec Circular Knife Type RSSL-301 is delivered with a Ø500 mm knife blade for cutting pork middles into loin and belly. The circular knife is adjustable in angle for optimized yield.

Type RSSL-501- Multi cut

Complete cutting arrangement

The circular knife for cutting of pork halves type RSSL-501 is used for multi-cuts and is delivered with a Ø650 mm knife blade. The unit is equipped with a high-quality stainless-steel blade and a long extension arm of 1,150 mm for optimized manual cutting. The knife is supplied with a fitted laying down roller arrangement, which is prepared for the additional mounting of a hind foot knife.

Functionality

The blades used are specially developed to meet the high demands in the meat industry for clean cuts and less bone dust. Additionally, a laser marking unit can be added to ensure the operator positions the carcass correctly.

Contact

CN: shanghai@frontmatec.com
Phone: +86 215 859 4850

DK: tandslet@frontmatec.com
Phone: +45 744 076 44

NL: rjjsen@frontmatec.com
Phone: +31 886 294 000

UK: birmingham@frontmatec.com
Phone: +44 121 313 3564

DE: beckum@frontmatec.com
Phone: +49 252 185 070

ES: barcelona@frontmatec.com
Phone: +34 936 438 000

RU: moscow@frontmatec.com
Phone: +7 495 424 9559

US: kansascity@frontmatec.com
Phone: +1 816 891 2440

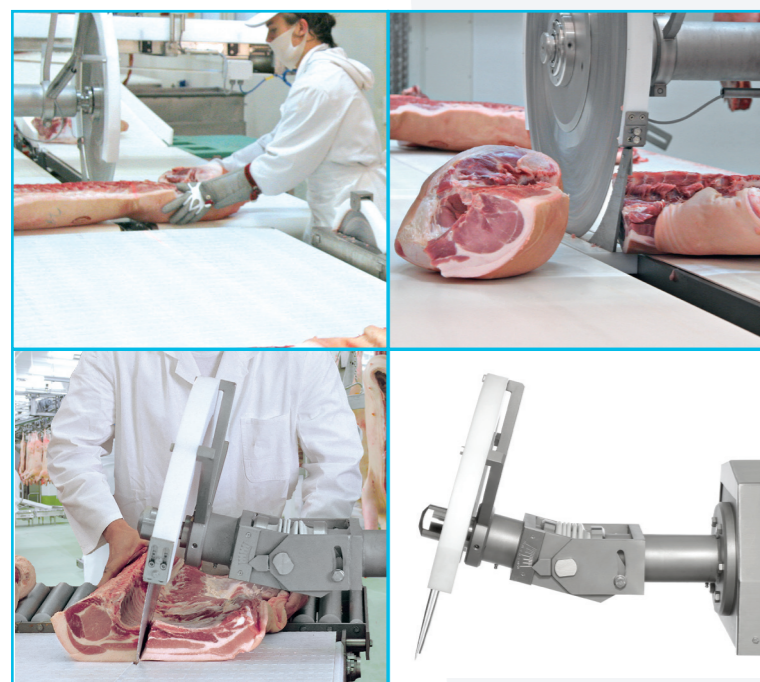

RSSL

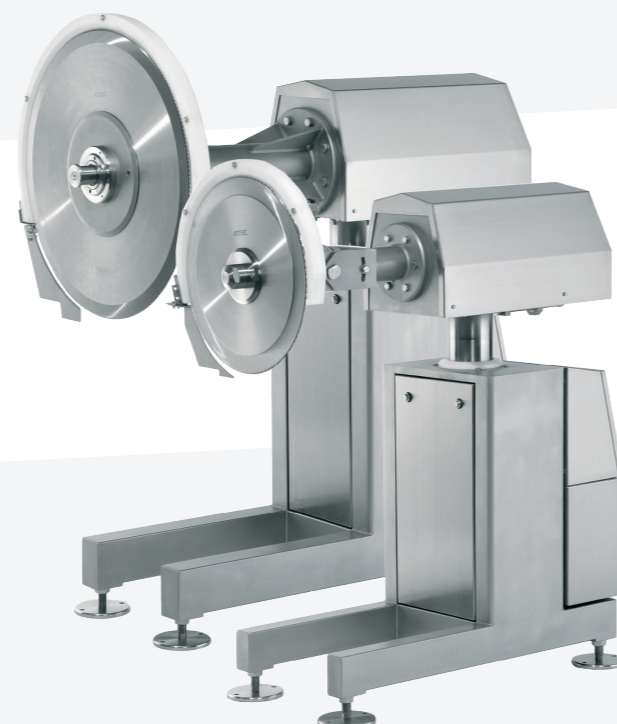

RSSL-108/-109/-110 and RSSL-301



BTSL



RSSL-501



RSSL-260

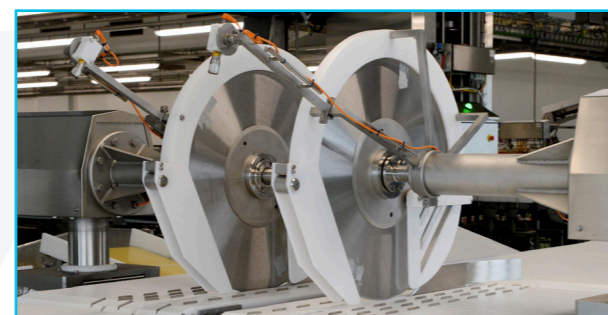

Optional laser marking unit

Technical data RSSL-108/-109/-110

Capacity	Up to 1,000 hour - depending on operator
Length	1,440 mm - normal extension arm (RSSL-108) 1,800 mm - long extension arm (RSSL-109)
Width	520 mm
Height	1,470 mm +/- 20 mm - adjustable
Products	Pork primals
Product temperature	Min. 3°C - max. 7°C
Blade dimensions	Ø750, Ø950
Voltage	3x400V, 50 Hz
Power	IN 6 Amp
Prefuse	10A

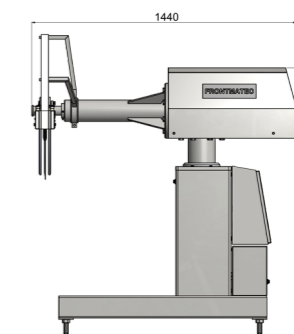

Type RSSL-108

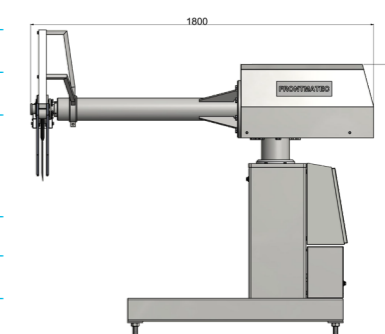

Type RSSL-109

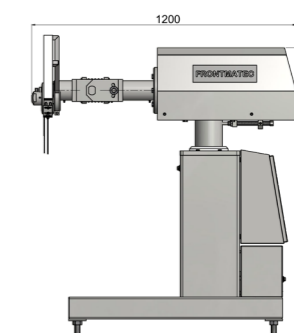

Type RSSL-301

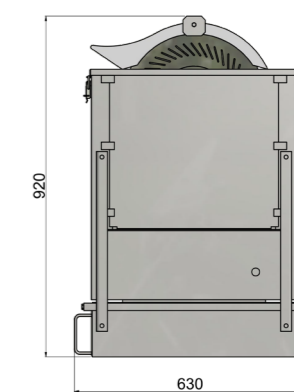

Type BTSL-100

Technical data RSSL-301

Capacity	Up to 800 /hour depending on operator
Length	1,200 mm
Width	540 mm
Height	1,325 mm +/- 40 mm - adjustable
Products	Pork middles
Product temperature	Min. 3°C - max. 7°C
Blade dimensions	Ø500 standard (optional Ø600)
Voltage	3x400V, 50 Hz
Power	IN 6 Amp
Prefuse	10A

Technical data BTSL-100/200

Capacity	Depending on operator
Version	Stand alone or mounted on conveyor
Length	630 mm
Width	630 mm
Height	920 mm
Products	Pork legs
Product temperature	Min. 3°C - max. 7°C
Blade dimensions	Ø400
Voltage	3x400V, 50 Hz
Power	IN 5 Amp
Prefuse	10A

Technical details are subject to alterations. The equipment is CE approved and designed in accordance with the EU regulations to meet the strictest demand on health and safety.